



Optical Fiber Cable Specification

ADSS

www.phoslinc.com

All rights reserved



1. Cable Construction

1.1 Cable cross-section

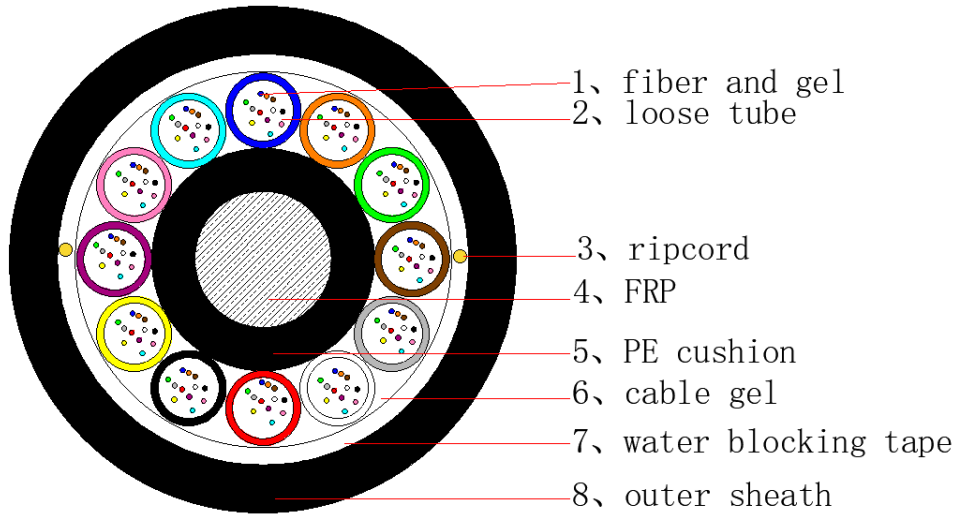

2. Cable Specification

2.1 Fiber and loose tube Color Code

No.	1	2	3	4	5	6
Color	Blue	Orange	Green	Brown	Grey	White
No.	7	8	9	10	11	12
Color	Red	Black	Yellow	Purple	Pink	Aqua

The color of the fillers will be natural.

2.2 Cable configuration

Item	contents	Value	
		96	144
Loose tube	Material	PBT	
	diameter(mm)	2.5	
	Type of filling compound	Jelly	
	Number	8	12
Filler	Material	PP	
	Number	0	
Max. fiber counts per tube	G.652D	12	
Central strength member	Material	FRP	
Water blocking	Material	Cable gel and water blocking tape	
Ripcord	Number	2	
Outer sheath	Material	HDPE	
	Color	Black	
Cable diameter(mm) (± 0.5)		12.8	15.8
Cable weight (kg/km) ($\pm 20\%$)		134	204

Note: The outer diameter of the cable in the table is for reference. The actual OD value after commissioning production shall prevail.

2.3 Mechanical Performance of Cable

Tensile performance(N)	Crush(N/100mm)
short term	Short term
2300	1000

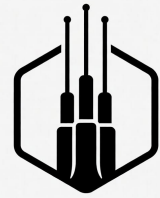

phoslinc

2.4 Minimum Allowable Bending Radius

Static: 12.5D

Dynamic: 25D

D is the out diameter of the cable

3. Mechanical, Electrical and Environmental Test Characteristics

Item	Test Method	Requirements
Tensile performance	IEC 60794-1-21-E1 Load: Tensile Strength Cable length under tension: Not less than 50m. Duration of load sustain: 1min. Velocity of transfer device: 10mm/min	The increase in attenuation shall not exceed 0.15dB, and fiber strain should not higher than 0.6% under load. No attenuation increase after test at 1550nm. Under visual examination without magnification, no damage to the sheath or to the cable elements after test.
Crush	IEC 60794-1-21-E3 Load and Duration: Short term load 1000N/100mm for 1 min. Number of tests: 3 Spacing between test places: 500 mm	Under short term load, the increase in attenuation shall less than 0.1dB at 1550 nm after the test. Under visual examination without magnification, no damage to the sheath or to the cable elements. The imprint of the striking surface on the sheath is not considered mechanical damage.
Impact	IEC 60794-1-21-E4 Impact energy: 4.5 J with striking surface radius of 300 mm; Number of impacts: 1, each at 3 different places spaced not less than 500mm apart.	No change in attenuation after test at 1550nm. Under visual examination without magnification, no damage to the sheath or to the cable elements. The imprint of the striking surface on the sheath is not considered mechanical damage.
Repeated bending	IEC 60794-1-21-E6 Bending radius: 20times cable diameter Cycles: 25 Load: 150N Duration of cycle: Approximately 2s.	No change in attenuation at 1550nm after test. Under visual examination without magnification, no damage to the sheath or to the cable elements
Torsion	IEC 60794-1-21-E7 Cycles: 10 Length under test: 1.0 m Turns: $\pm 180^\circ$ Load: 150N	Under visual examination without magnification, there shall be no damage to the sheath or to the cable elements. The variation in attenuation for each fibre shall be ≤ 0.10 dB at 1550 nm during the test and no permanent change after test.
Temperature cycling	IEC 60794-1-22-F1 Sample length: at least 1000m	The change in attenuation coefficient shall be less than 0.10 dB/km at 1550nm.

	Temperature range: -40°C ~ +70°C Cycles:2 Temperature cycling test dwell time: 12 hours	
Water Penetration	IEC 60794-1-22-F5B Time : 24 hours Sample length : 3m Water height : 1m	No water shall be detected at the unsealed end of the sample during and at the end of the test.
Compound flow	IEC 60794-1-22-F16 Temperature:70C Sample count:5 Sample length:200 ±5 mm, Remove length: 100 ±2,5 mm, Time:24h	No filling compound dripped.
Other parameters	According to IEC 60794	

Remark: "No attenuation changes" is considered as the attenuation changes ≤ 0.05 dB.

4. Optical properties of the SM fiber is according to ITU-T G.652D standard requirements.

G652D:

Description	Specification	
	After Cable	
Mode Field diameter @1310nm	9.2±0.4μm	
Mode Field diameter @1550nm	10.4±0.5μm	
Cladding diameter	125.0± 1μm	
Core concentricity error	≤0.6μm	
Cladding non-concircularity	≤ 0.8%	
Coating diameter	245±10μm (Before colored)	
	250±15μm (colored)	
Coating/cladding concentricity error	≤ 12μm	
Cable cutoff wavelength	≤1260 nm	
Point discontinuity	≤0.05dB	
Attenuation coefficient @ 1310 nm	≤0.4dB/km	
	@ 1383 nm	≤0.4
	@ 1550 nm	≤0.3dB/km
	@ 1625nm	≤0.24dB/km
Macro-bend induced attenuation		

100 turns, 30mm radius @1550n/1625m	≤0.05dB
PMD	
Max. individual fiber	≤0.2 ps/km ^{1/2}
PMD _Q	≤0.1 ps/km ^{1/2}
Zero-dispersion wavelength	1300 ~ 1324 nm
Zero-dispersion slope	≤ 0.092 ps/(nm ² .km)
Chromatic dispersion coefficient	
@ 1288-1339 nm	≤3.5ps/(nm. km)
@ 1271-1360nm	≤5.3ps/(nm. km)
@ 1550 nm	≤18ps/(nm. km)
@ 1625 nm	≤22ps/(nm. km)
Proof test level	100 kpsi (0.69 Gpa), 1% strain
Coating strip force(peak value)	1.3~8.9N
Fiber curl (Radius)	≥ 4 m

5. Cable Sheath Marking

Unless otherwise specified, the cable sheath marking shall be in accordance with follows:

Color: white

Contents: PHOSLINC, the type of cable, the year of manufacture, length marking

Interval: 1m

6. Cable tray structure

d1—Outer circle diameter; d2—Inner diameter;

L1—Outer width; L2—Inside width;

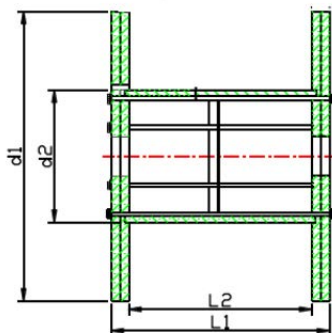

Cable Shape size (3Km/Drum):

Core(F)	d1(mm)	d2(mm)	L2(mm)	L1(mm)	Weight of drum (kg)	Weight of drum with cable(kg)
96	1230	450	650	750	61	499
144	1500	600	630	750	96	757

(End of Specification)